

## INDEX

SHEET NO.	SUBJECT
1	Traffic Control Devices Index and General Notes
2	Channelizing Devices
3	Merge or Shift Taper
4	Channelizing Devices Usage
5	Type III Barricade
6	Typical Construction Sign Mounting
7	Type III Barricade Application for Road Closure for Thru Traffic
8	Type III Barricade Application for Road Closure to All Traffic
9	U Channel Steel Post Splice Detail
10	Temporary Transverse Rumble Strips
11	Worksite Speed Limit Sign Assembly
12	Worksite Speed Limit Sign Assembly Longitudinal Placement

### GENERAL NOTES:

1. Unless otherwise noted, channelizing devices in tangent sections shall be 100 ft where the permanent posted speed limit is 50 m.p.h. or greater, and the spacing shall be 50 ft where the permanent posted speed limit is less than or equal to 45 m.p.h.
2. Unless otherwise noted, the spacing of channelizing devices in tapers shall be equal in feet to the permanent posted speed limit in m.p.h.
3. All channelizing devices shall satisfy NCHRP 350 or MASH crash evaluation criteria.
4. It is not necessary to delineate a drop-off of 3 in. or less adjacent to active travel lanes. Where channelizing devices are used to delineate drop-offs of 3 in. or less adjacent to active travel lanes, at least 33 in. of the device shall be above the adjoining pavement surface. Where channelizing devices are used to delineate a drop-off greater than 3 in. adjacent to active travel lanes, at least 27 in. of the device shall be above the adjoining pavement surface and a Type C warning light shall be attached to the top of the device (on the pavement side). In no case shall more than 9 in. of the device be below the adjoining pavement surface.
5. The proper orientation in respect to approaching vehicular traffic shall be maintained on channelizing devices. Drums are the preferred channelizing device in a tight radius curve and at intersections.
6. **Short-term stationary**, work that occupies a location for more than one hour within a single daylight period.  
**Intermediate-term stationary**, work that occupies a location for more than one daylight period up to three days, or nighttime work lasting more than one hour.  
**Long-term stationary**, work that occupies a location for more than three days.

INDIANA DEPARTMENT OF TRANSPORTATION

TRAFFIC CONTROL DEVICES  
INDEX AND GENERAL NOTES

SEPTEMBER 2022

STANDARD DRAWING NO. E 801-TCDV-01

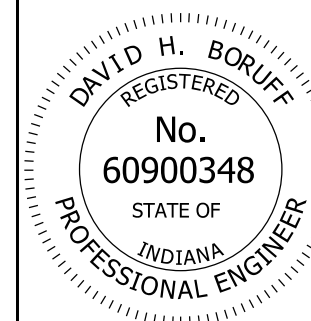

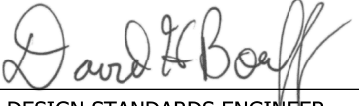
  
 06/08/22  
 DESIGN STANDARDS ENGINEER      DATE

  
 06/27/2022  
 CHIEF ENGINEER      DATE

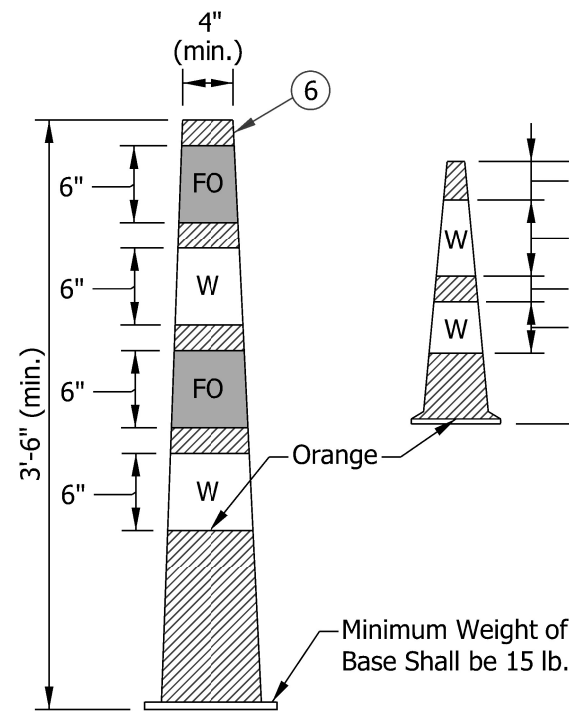

**CONE**  
③

③

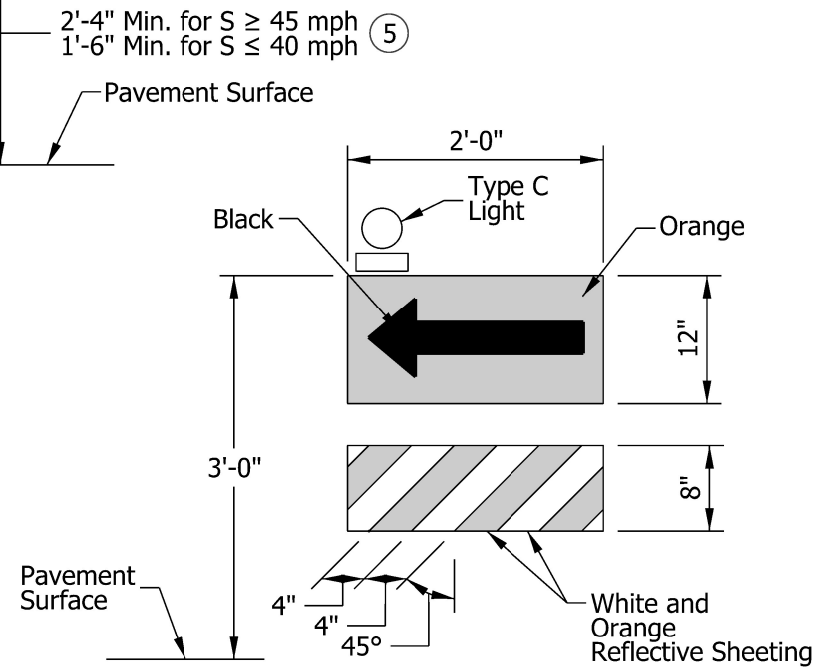

**DIRECTION INDICATOR BARRICADE**

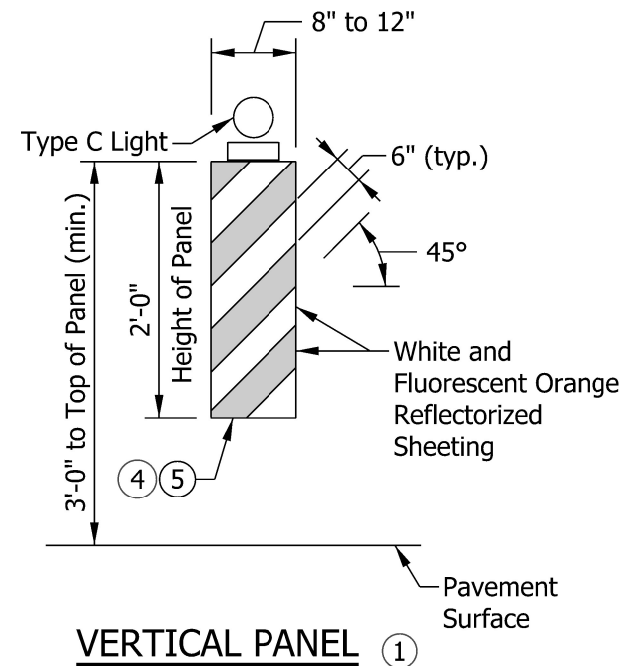

**VERTICAL PANEL** ①

①

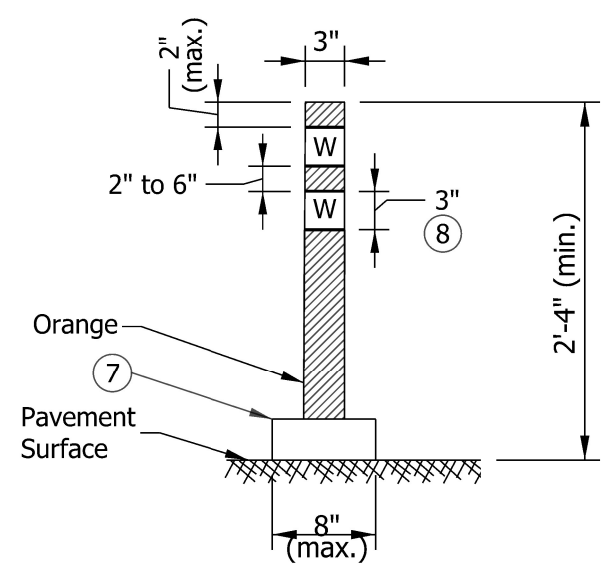

**FLEXIBLE TUBULAR MARKER**

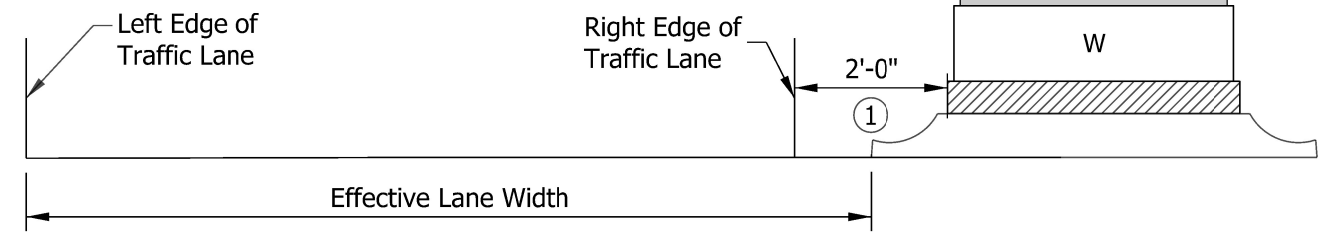

**PLACEMENT OF CHANNELIZING DEVICES**

①

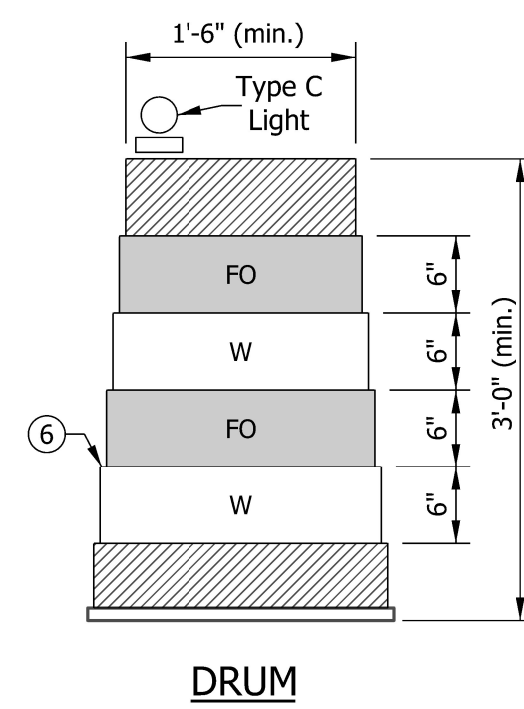

**DRUM**

**NOTES:**

- ① Shy distance for tubular markers and cones may be reduced to 1 ft.
2. A Type C warning light will be required on tapers where there is a reduction in the number of lanes and a flashing arrow sign is used.
- ③ Reflective sheeting may be omitted from cones for lane closures during daylight hours.
- ④ For vertical panels equal to or greater than 3 ft in height, the width of the stripes shall be 6 in.
- ⑤ Vertical panels used on roadways with a permanent posted speed limit of 50 mph or greater shall have a minimum reflective panel area of 270 sq. in.
- ⑥ The maximum distance between the edges of adjacent reflective sheeting strips shall be 2 in.
- ⑦ Minimum flexible tubular marker base area shall be 0.3 sq ft.
- ⑧ For nighttime work, tubular markers with a height of less than 3.5 ft shall have two 3 in. white bands of reflective sheeting placed a maximum of 2 in. from the top with a maximum of 6 in. between the bands.
9. See Standard Drawing E 801-TCDV-04 for channelizing device usage and application.

**LEGEND**

- W = White Reflective Sheeting
- FO = Fluorescent Orange Reflective Sheeting

<b>INDIANA DEPARTMENT OF TRANSPORTATION</b>	
<b>CHANNELIZING DEVICES</b>	
<b>SEPTEMBER 2022</b>	
<b>STANDARD DRAWING NO. E 801-TCDV-02</b>	
	<p style="text-align: right;">06/08/22 DESIGN STANDARDS ENGINEER DATE</p> <p style="text-align: right;">06/27/2022 CHIEF ENGINEER DATE</p>

**NOTES:**

1. For freeways, a taper length of 840 ft shall be used for the first merge taper. For subsequent merges, a length of 840 ft shall be used unless otherwise shown on the plans.
2. A shift taper preceded by a merge taper shall be separated by a tangent section equal to or greater than the length of the shift taper.

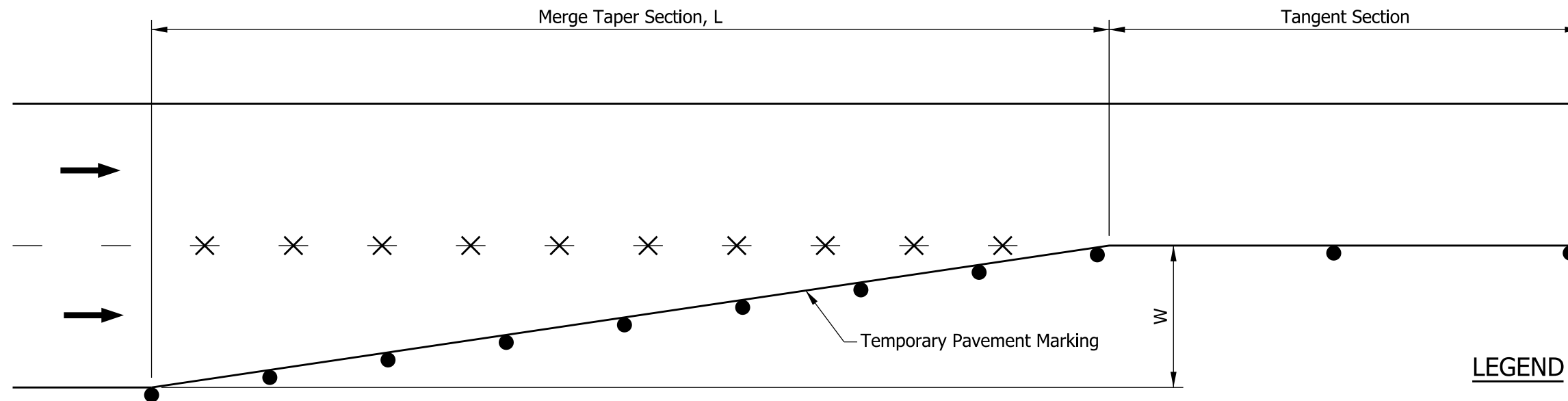

**LEGEND**

- = Channelizing Device
- \* = Removal of pavement markings and prismatic reflectors
- ➔ = Direction of Traffic
- L = Minimum length of taper in ft
- S = Posted speed limit prior to the construction zone in mph
- W = Width of lane or shift in ft

MERGE TAPER				
S	Min. Taper Length L			
MPH	W = 9	W = 10	W = 11	W = 12
25	95	105	115	125
30	135	150	165	180
35	185	205	225	245
40	240	270	295	320
45	405	450	500	540
50	450	500	550	600
55	495	550	605	660
60	540	600	660	720
65	585	650	715	780
70	630	700	770	840
75	675	750	825	900

For W not shown in the table,  $L = W \times S$  for a speed of 45 mph or greater.  
 $L = W \times S^2/60$  for a speed of 40 mph or lower.

SHIFT TAPER				
S	Min. Taper Length L/2			
MPH	W = 9	W = 10	W = 11	W = 12
25	50	55	60	65
30	70	75	85	90
35	95	105	115	125
40	120	135	150	160
45	205	225	250	270
50	225	250	275	300
55	250	275	305	330
60	270	300	330	360
65	295	325	360	390
70	315	350	385	420
75	340	375	415	450

For W not shown in the table, L is one half that required for a merge taper.

INDIANA DEPARTMENT OF TRANSPORTATION	
MERGE OR SHIFT TAPER	
SEPTEMBER 2022	
STANDARD DRAWING NO.	E 801-TCDV-03
	 DESIGN STANDARDS ENGINEER      06/08/22 DATE
 CHIEF ENGINEER	06/27/2022 DATE

**NOTES:**

Channelizing Device Type	Usage Application									
	To delineate merge tapers on		To delineate tangents where adequate space exists and also lane shift tapers on		Where the effective lane width is less than 10 ft to delineate tangents in lieu of drums on		Where the effective lane width is less than 10 ft to delineate edge of pavement drop-off in lieu of drums on		To divide opposing lanes of traffic on	To divide two or more lanes of same direction traffic on
	Freeways	Non-Freeways	Freeways	Non-Freeways	Freeways	Non-Freeways	Freeways	Non-Freeways	Non-Freeways	Non-Freeways
18 in. Cone ① ≤ 40 mph Posted Speed Limit	No	Yes ④	No	Yes ④	No	No	No	No	Yes ④	Yes ④
18 in. Cone ≥ 45 mph Posted Speed Limit	No	No	No	No	No	No	No	No	No	No
28 in. Cone ① ≤ 40 mph Posted Speed Limit	No	Yes ⑤	No	Yes ⑤	No	No	No	No	Yes ⑤	Yes ⑤
28 in. Cone ② 45 mph Posted Speed Limit	No	Yes ④	No	Yes ④	No	No	No	No	Yes ⑤	Yes ⑤
28 in. Cone ≥ 50 mph Posted Speed Limit	No	Yes ④	No	Yes ④	No	No	No	No	Yes ⑤	Yes ⑤
42 in. Channelizer (Cone) ① ⑥ ≤ 45 mph Posted Speed Limit	No	Yes ⑤	No	Yes ⑤	Yes	Yes	Yes	Yes	Yes ⑤	Yes ⑤
42 in. Channelizer (Cone) ② ⑥ ≥ 50 mph Posted Speed Limit	No	Yes ⑤	No	Yes ⑤	Yes	Yes	Yes	Yes	Yes ⑤	Yes ⑤
Direction Indicator Barricade ③	Yes	Yes	No	No	No	No	No	No	No	No
Flexible Tubular Marker ③	No	No	No	No	No	No	No	Yes	Yes	Yes
Vertical Panel ③	No	Yes	No	Yes	No	Yes	No	Yes	No	No
Construction Drum ③	Yes	Yes	Yes	Yes	No	No	No	No	No	No

- ① Spacing in tangent shall be 40 ft maximum; spacing between devices in taper shall be numerically equal in feet, maximum, to the posted speed limit in m.p.h.
- ② Spacing in tangent shall be 80 ft maximum; spacing between devices in taper shall be numerically equal in feet, maximum, to the posted speed limit in m.p.h.
- ③ Spacing in tangents shall be 50 ft maximum when the speed limit is 45 m.p.h. or below; spacing in tangents shall be 100 ft maximum when the posted speed limit is 50 mph or above; in cases where the posted speed limit is intermittently set to 45 m.p.h. the channelizing devices shall be maintained at 90 ft maximum spacing; spacing of channelizing devices on tapers shall be numerically equal in feet, maximum, to the posted speed limit in m.p.h.
- ④ May only be used for daylight restrictions.
- ⑤ May not be used for long-term, stationary work (more than 3 days).
- ⑥ 30 lb ballast configuration required.
- 7. For the purpose of channelizing device usage and spacing, the posted speed limit is the permanent posted speed limit, temporary speed limit, or worksite speed limit, whichever is lower.

**CHANNELIZING DEVICE USAGE TABLE**

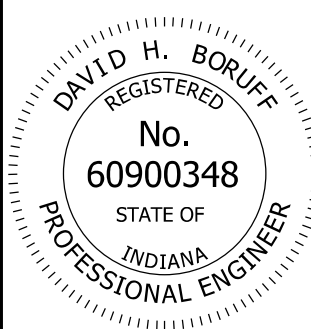
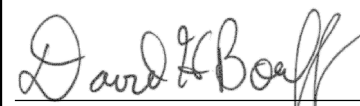
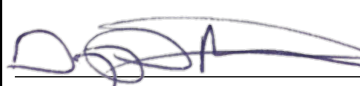
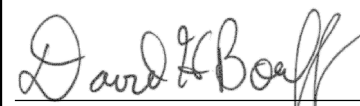
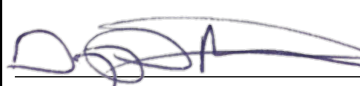
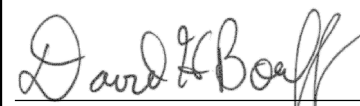
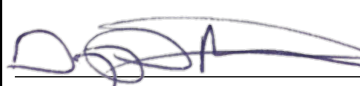
INDIANA DEPARTMENT OF TRANSPORTATION									
CHANNELIZING DEVICE USAGE									
SEPTEMBER 2022									
STANDARD DRAWING NO. E 801-TCDV-04									
	<table style="width: 100%; border-collapse: collapse;"> <tr> <td style="text-align: right; width: 80%;"></td> <td style="text-align: right; width: 20%;">06/08/22</td> </tr> <tr> <td style="text-align: right;">DESIGN STANDARDS ENGINEER</td> <td style="text-align: right;">DATE</td> </tr> <tr> <td style="text-align: right; width: 80%;"></td> <td style="text-align: right; width: 20%;">06/27/2022</td> </tr> <tr> <td style="text-align: right;">CHIEF ENGINEER</td> <td style="text-align: right;">DATE</td> </tr> </table>		06/08/22	DESIGN STANDARDS ENGINEER	DATE		06/27/2022	CHIEF ENGINEER	DATE
	06/08/22								
DESIGN STANDARDS ENGINEER	DATE								
	06/27/2022								
CHIEF ENGINEER	DATE								

**NOTES:**

1. Barricade lights, signs, and supports shall satisfy NCHRP 350 or MASH crash evaluation criteria.
- ② The detour arrow sign shall be used only when a detour route has been signed.
- ③ The sign assembly shall be above the Type III barricade.

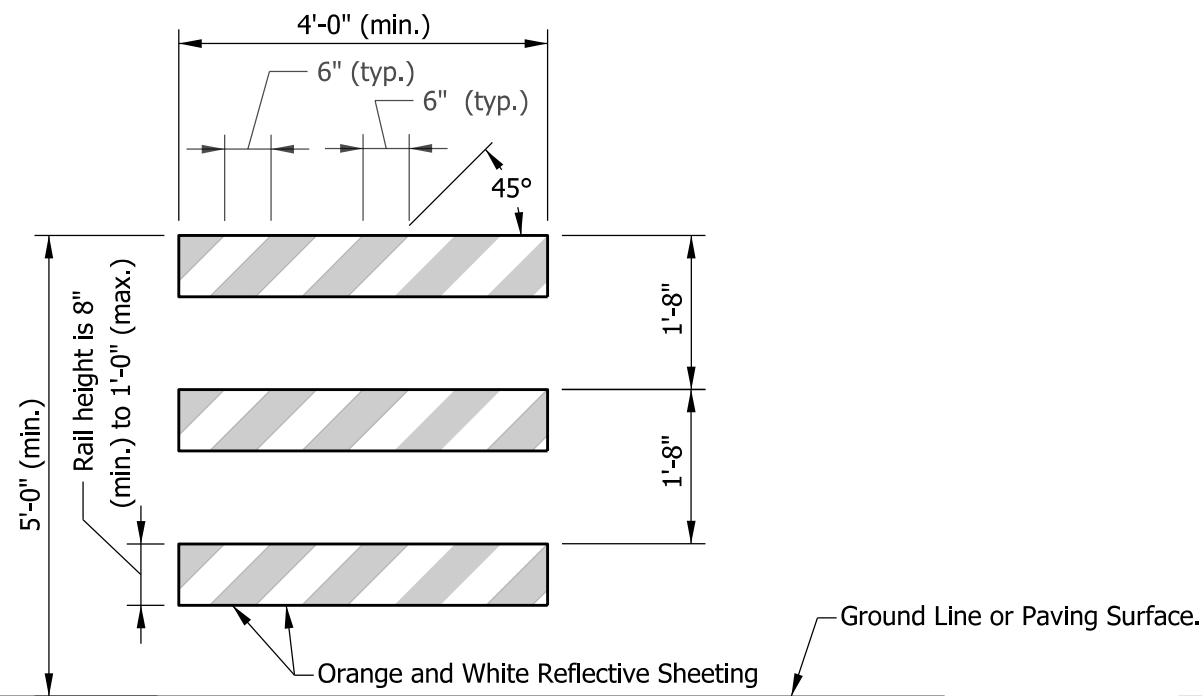

**TYPE III BARRICADE**

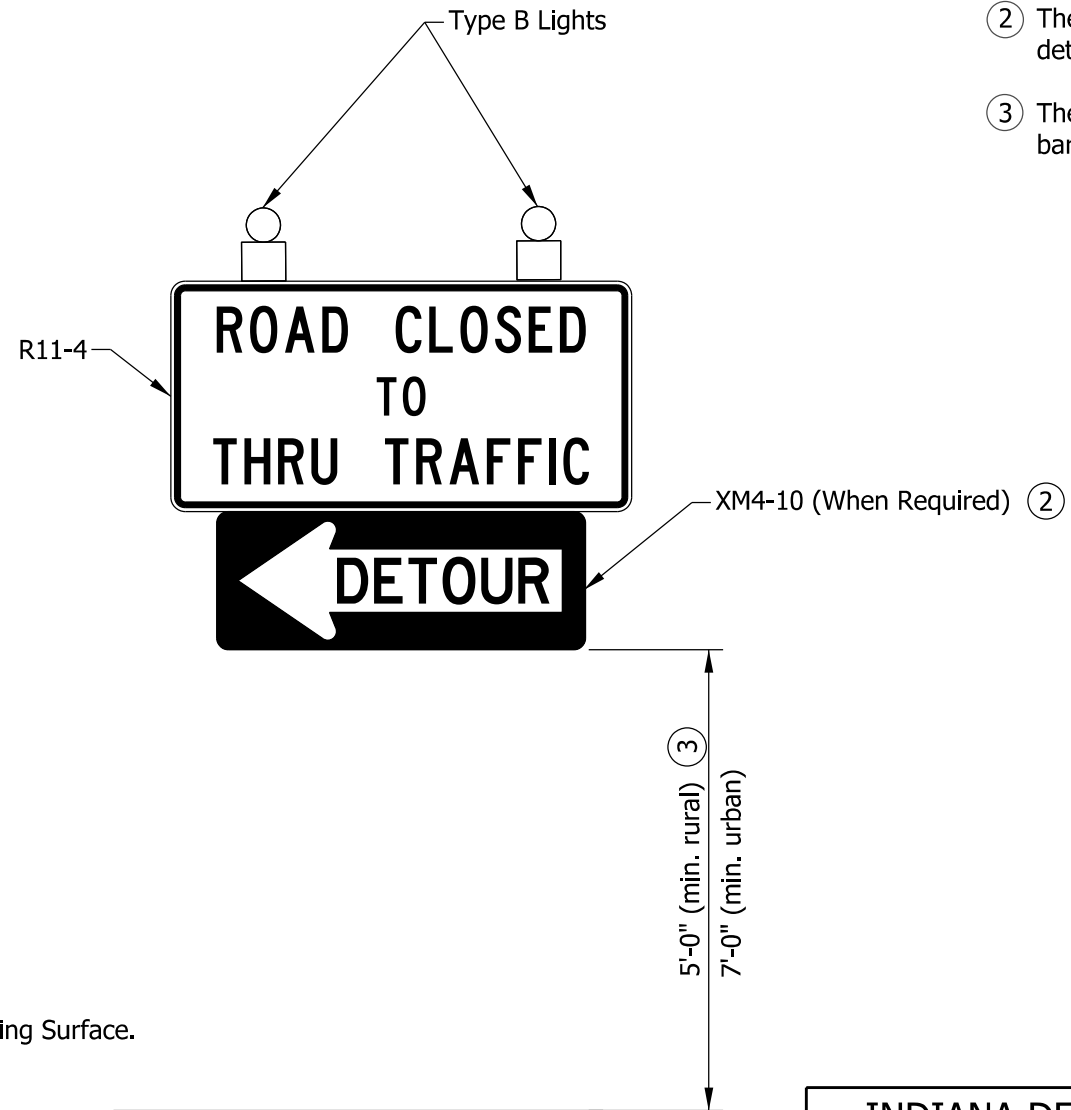

**ROAD CLOSURE SIGN ASSEMBLY**

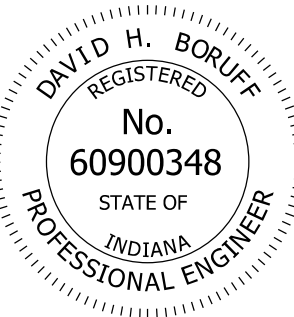
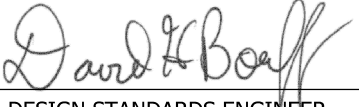
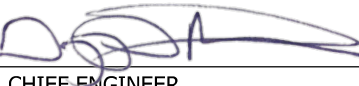
INDIANA DEPARTMENT OF TRANSPORTATION	
TYPE III BARRICADE	
SEPTEMBER 2022	
STANDARD DRAWING NO. E 801-TCDV-05	
	<div style="text-align: right;">               06/08/22              DESIGN STANDARDS ENGINEER      DATE         </div> <div style="text-align: right; margin-top: 20px;">               06/27/2022              CHIEF ENGINEER      DATE         </div>

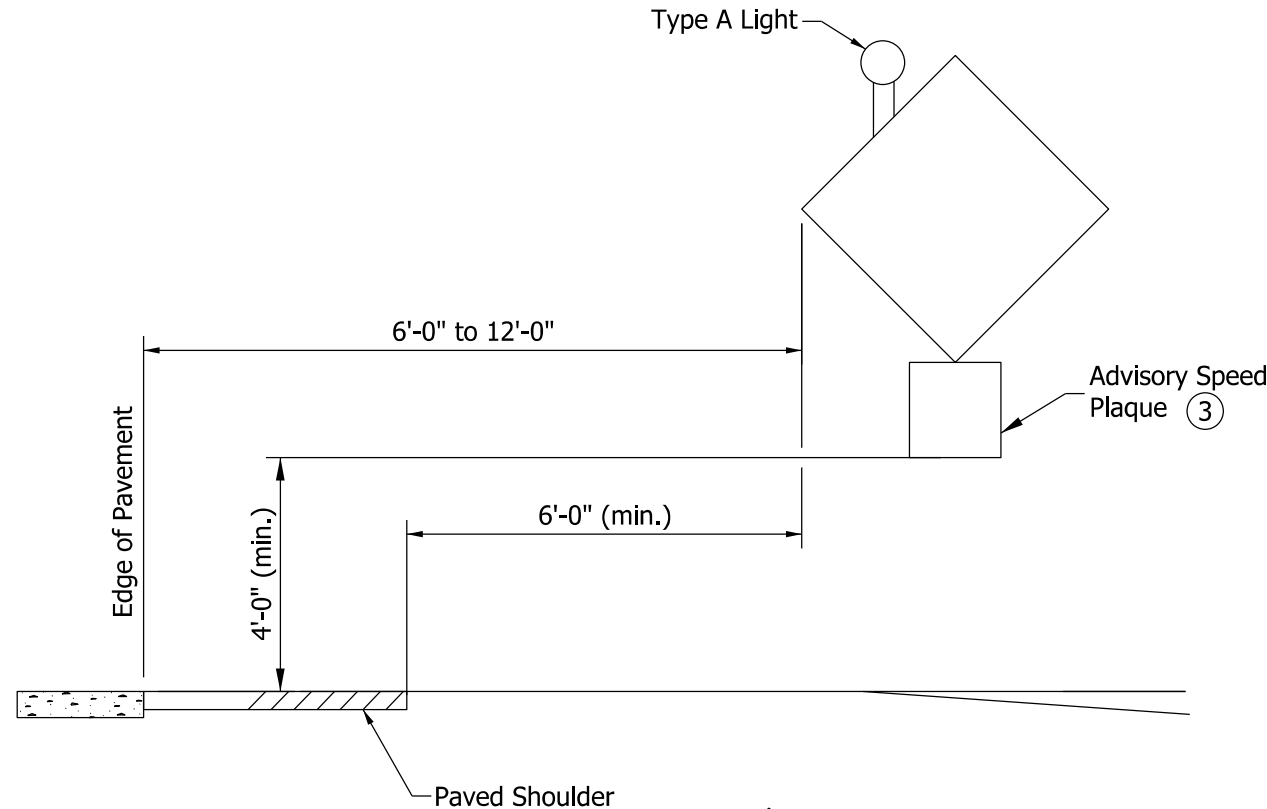
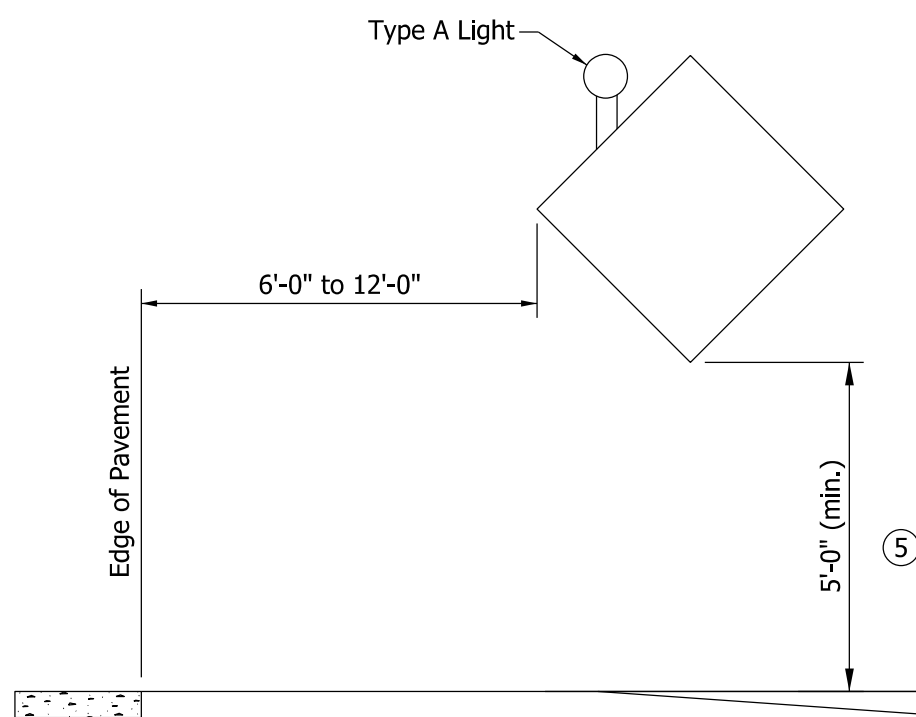

**ROADWAY WITHOUT CURB**

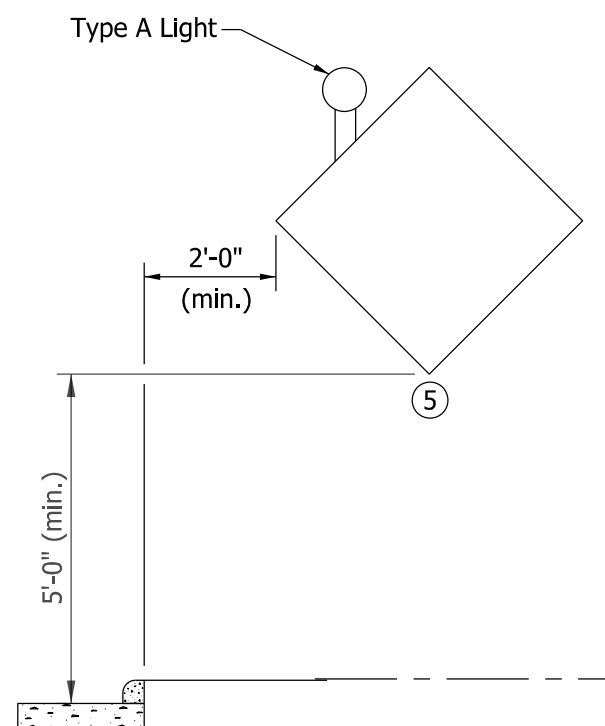
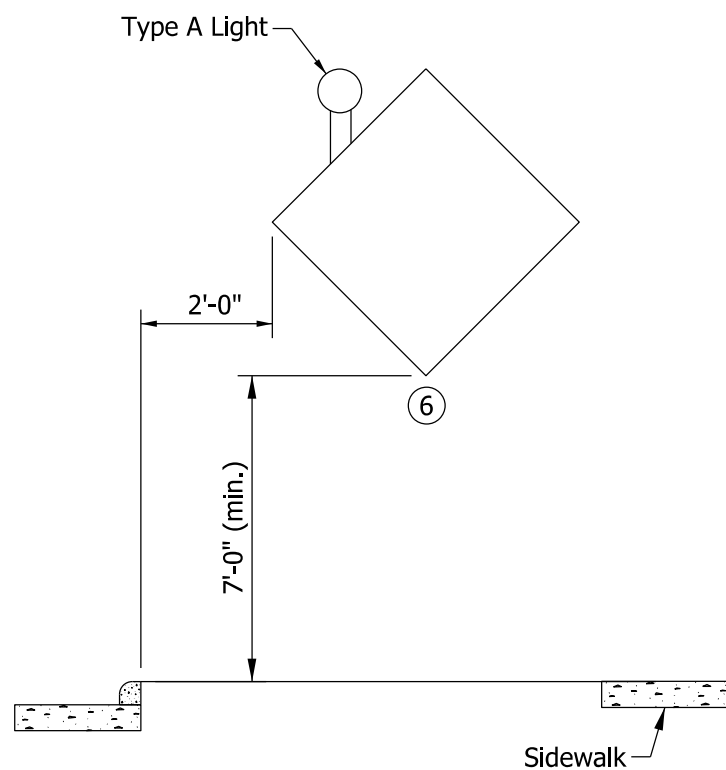

**CURBED ROADWAY**

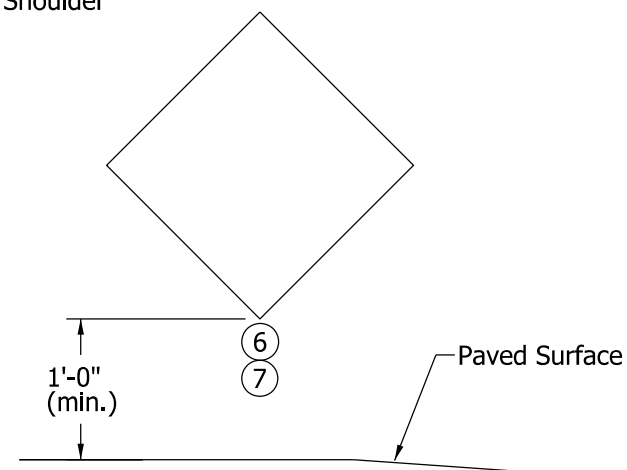

**TEMPORARY MOUNTED CONSTRUCTION SIGN**

**NOTES:**

1. See Standard Drawing E 801-TCSN-07 for additional notes.
2. Signs, lights, and supports shall satisfy NCHRP 350 or MASH crash evaluation criteria.
- ③ An advisory speed plaque, required to be placed with another construction sign, may be mounted on the post closest to the roadway at a height not less than 4 ft above the edge of pavement adjacent to the sign. The bottom of the construction warning sign shall not be lower than the top of the advisory speed plaque.
4. Type A warning light required on all construction signs.
- ⑤ In urban area or on Interstate route, mounting height shall not be less than 7 ft.
- ⑥ When signs are placed on sidewalk, a 4 ft useable width shall be maintained. No part of the sign or support that is less than 7 ft in height may protrude more than 4 in. into the 4 ft useable sidewalk width.
- ⑦ Temporary mounted construction sign for nighttime work or for operations which affect traffic lanes shall have a mounting height of 5 ft above the traveled way. On roadways where on-street parking is allowed, temporary mounted construction signs shall have a minimum sign mounting height of 7 ft above the traveled way.

<b>INDIANA DEPARTMENT OF TRANSPORTATION</b>	
<b>TYPICAL CONSTRUCTION SIGN MOUNTING</b>	
<b>SEPTEMBER 2022</b>	
<b>STANDARD DRAWING NO. E 801-TCDV-06</b>	
	06/08/22 DATE
	06/27/2022 DATE
	CHIEF ENGINEER

**NOTES:**

- ① The detour arrow (XM4-10) sign shall be used only when a detour route has been signed.
2. See Standard Drawing E 801-TCDV-06 for sign mounting information.
3. Barricades and supports shall satisfy NCHRP 350 or MASH crash evaluation criteria.
- ④ The R11-3a ("ROAD CLOSED/LOCAL TRAFFIC ONLY") sign may be substituted for the R11-4 sign as shown on the plans or as directed by the engineer.

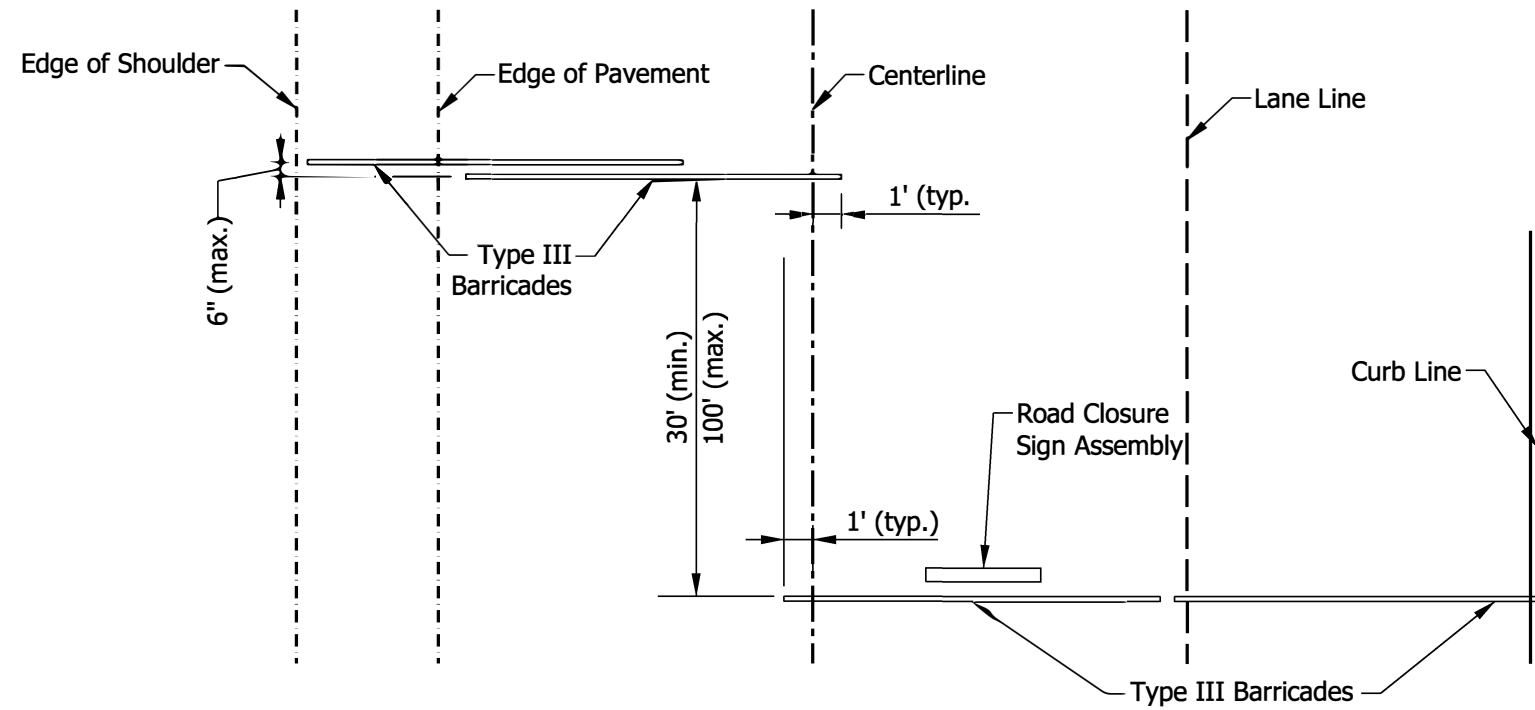

**PLAN VIEW**

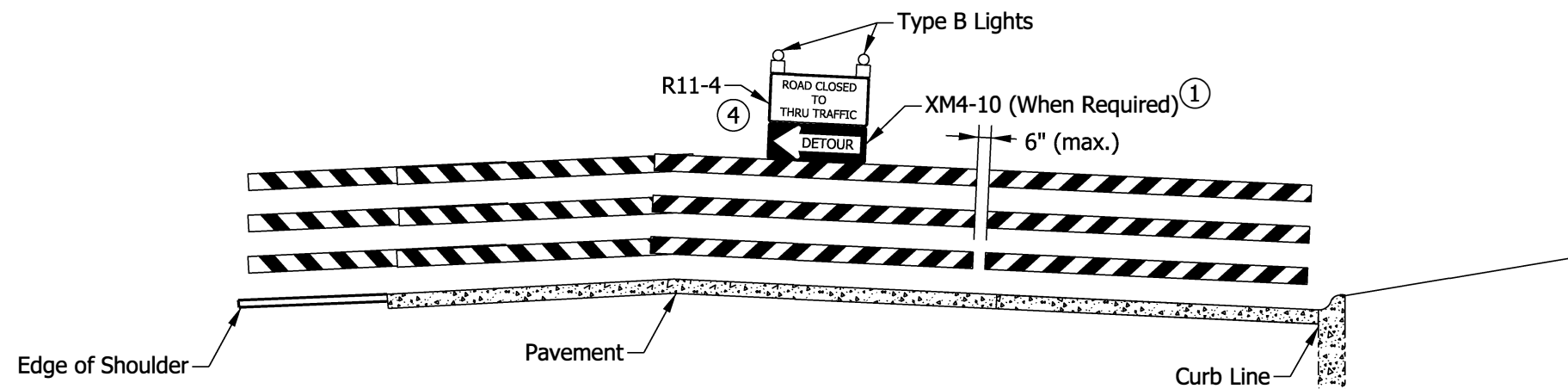

**ELEVATION**

INDIANA DEPARTMENT OF TRANSPORTATION

TYPE III BARRICADE APPLICATION FOR  
ROAD CLOSURE FOR THRU TRAFFIC

SEPTEMBER 2022

STANDARD DRAWING NO. E 801-TCDV-07

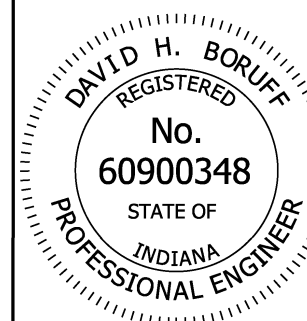

*David H. Boruff* 06/08/22  
DESIGN STANDARDS ENGINEER DATE

*[Signature]* 06/27/2022  
CHIEF ENGINEER DATE

**NOTES:**

- ① The detour arrow (XM 4-10) sign shall be used only when a detour route has been signed.
2. See Standard Drawing E 801-TCDV-06 for sign mounting information.
3. Barricades and supports shall satisfy NCHRP 350 or MASH crash evaluation criteria.
- ④ The sign legend of the R11-2 sign may be modified to "BRIDGE CLOSED" as shown on the plans or as directed by the engineer.
- ⑤ Barricades shall be supported on driven posts in areas outside of the pavement or sidewalk, where side slopes are 3 to 1 or flatter.

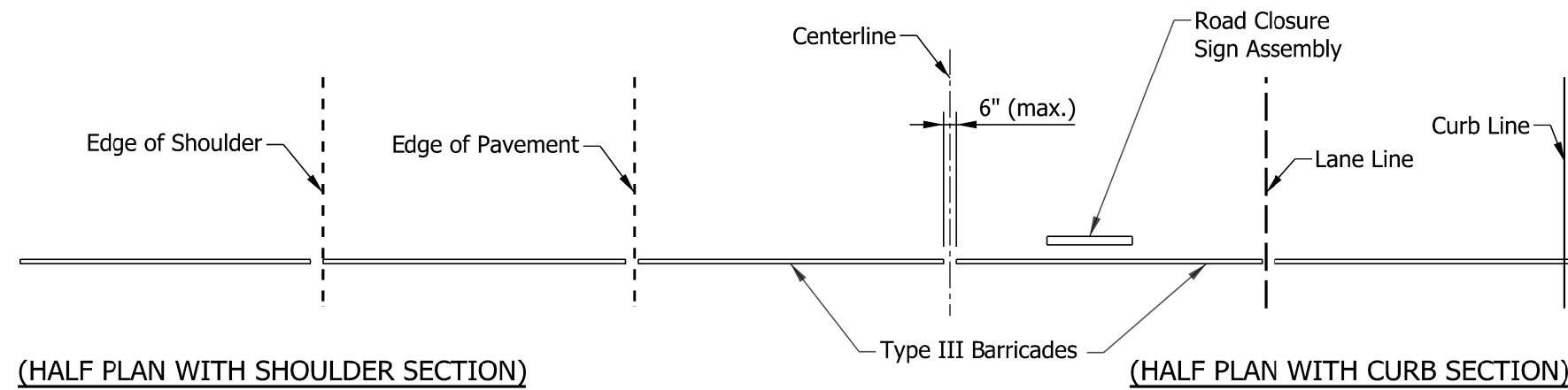

**PLAN VIEW**

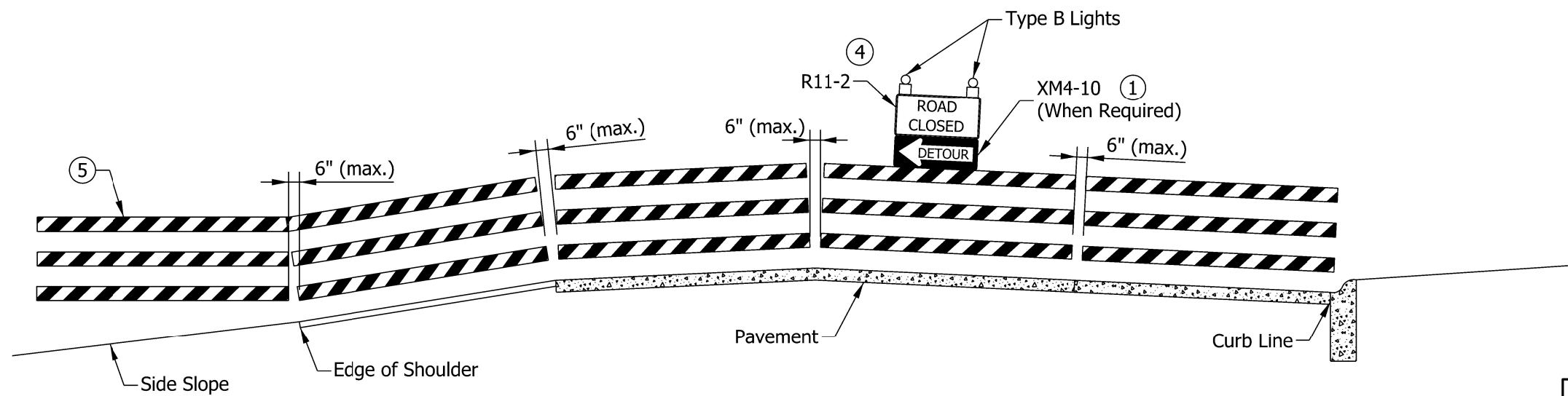

**ELEVATION**

INDIANA DEPARTMENT OF TRANSPORTATION

TYPE III BARRICADE APPLICATION  
FOR ROAD CLOSURE TO ALL TRAFFIC

SEPTEMBER 2022

STANDARD DRAWING NO. E 801-TCDV-08

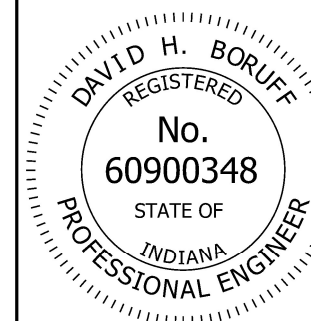

*David H. Boruff* 06/08/22  
DESIGN STANDARDS ENGINEER DATE

*[Signature]* 06/27/2022  
CHIEF ENGINEER DATE

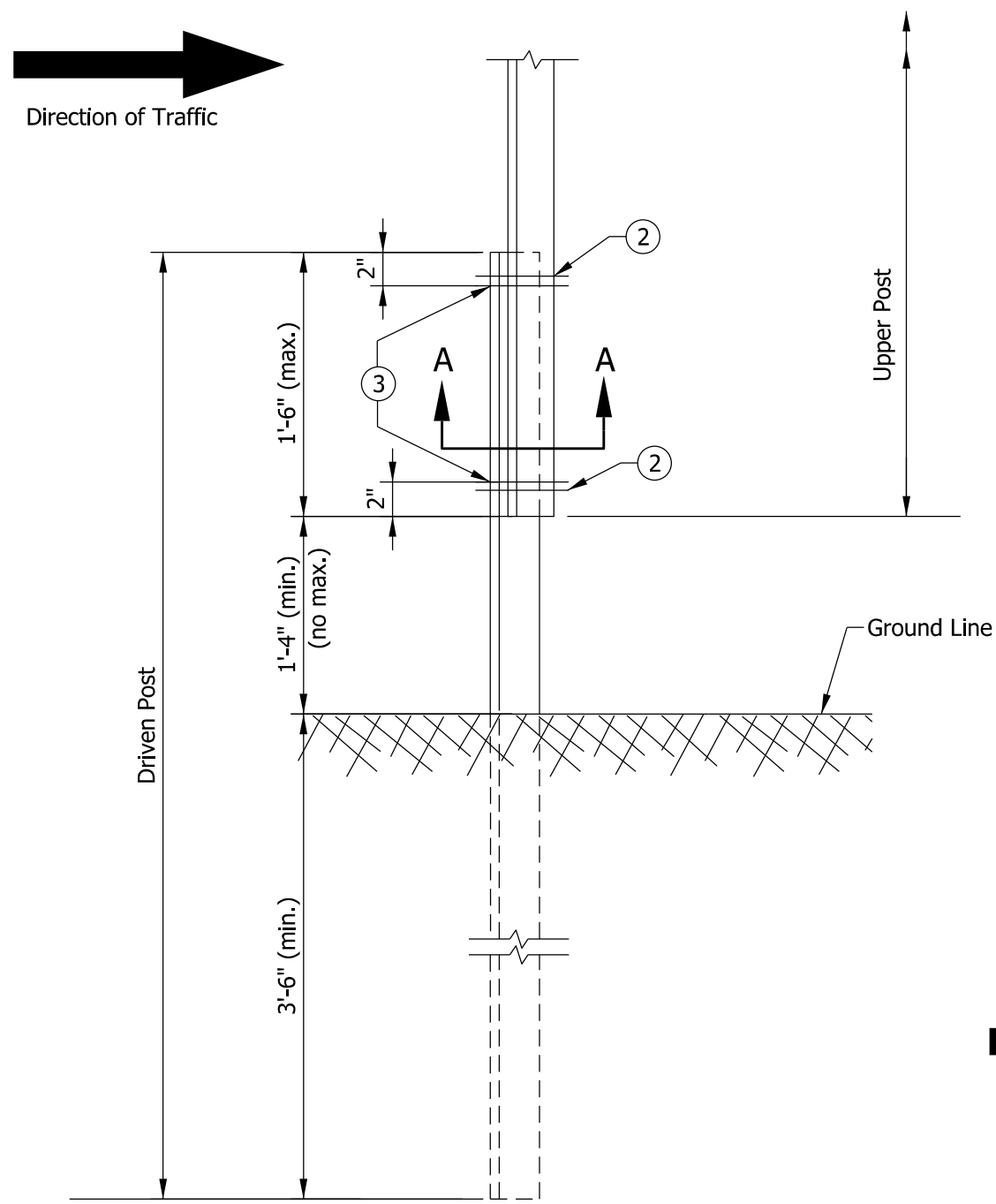

ELEVATION

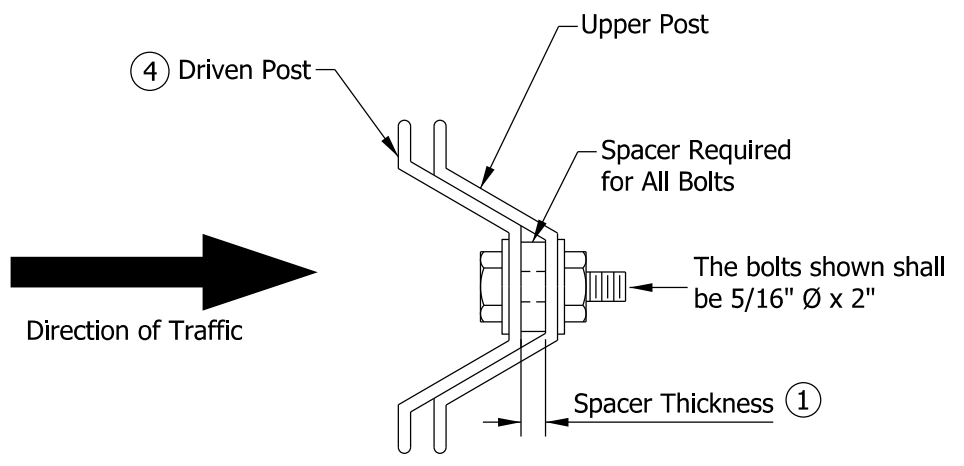



SECTION A-A

U CHANNEL STEEL POST SPLICE

NOTES:

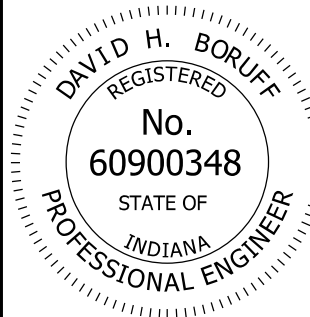
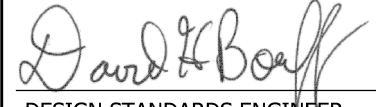
- ① The spacer thickness shall be 1/16 in. less than the gap between the posts when positioned in the unbolted configuration.
- ② The lower bolt, spacer, washer, and nut shall be installed in a prepunched hole within the first 2 in. of the end of the lapped post section.
- ③ The upper bolt, spacer, washer, and nut shall be installed in a prepunched hole within the first 2 in. of the lower bolt. The maximum spacing between the bolts shall be 1.5 ft. If the length of the post lap is increased such that this 1.5 ft maximum is exceeded, then interior bolts shall be installed such that the maximum space between adjacent bolts does not exceed the 1.5 ft limit.
- ④ The driven post shall be mounted in front of the upper post with respect to adjacent oncoming traffic, regardless of the direction the sign is facing.

INDIANA DEPARTMENT OF TRANSPORTATION	
U CHANNEL STEEL POST SPLICE DETAIL	
SEPTEMBER 2022	
STANDARD DRAWING NO.	E 801-TCDV-09
	<div style="display: flex; justify-content: space-between;"> <div style="text-align: center;">               DESIGN STANDARDS ENGINEER           </div> <div style="text-align: right;">             06/08/22              DATE           </div> </div> <div style="display: flex; justify-content: space-between; margin-top: 10px;"> <div style="text-align: center;">               CHIEF ENGINEER           </div> <div style="text-align: right;">             06/27/2022              DATE           </div> </div>

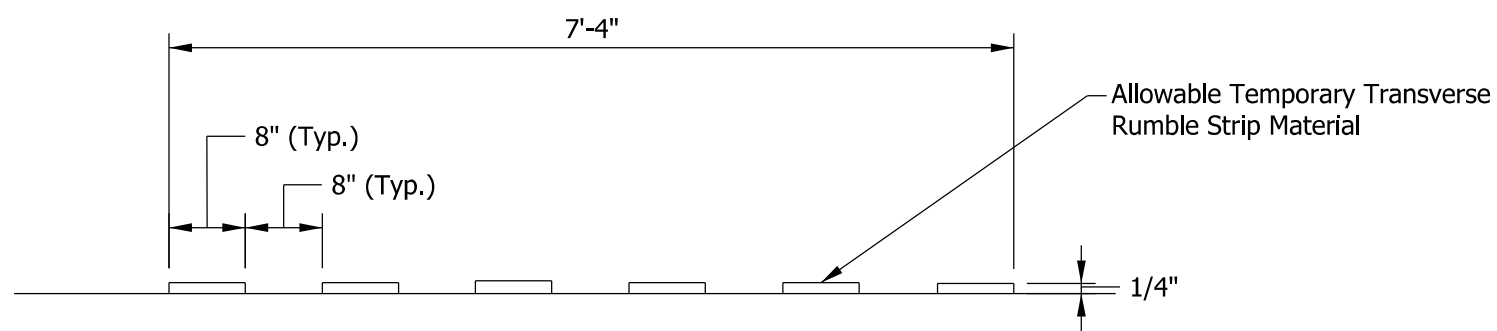
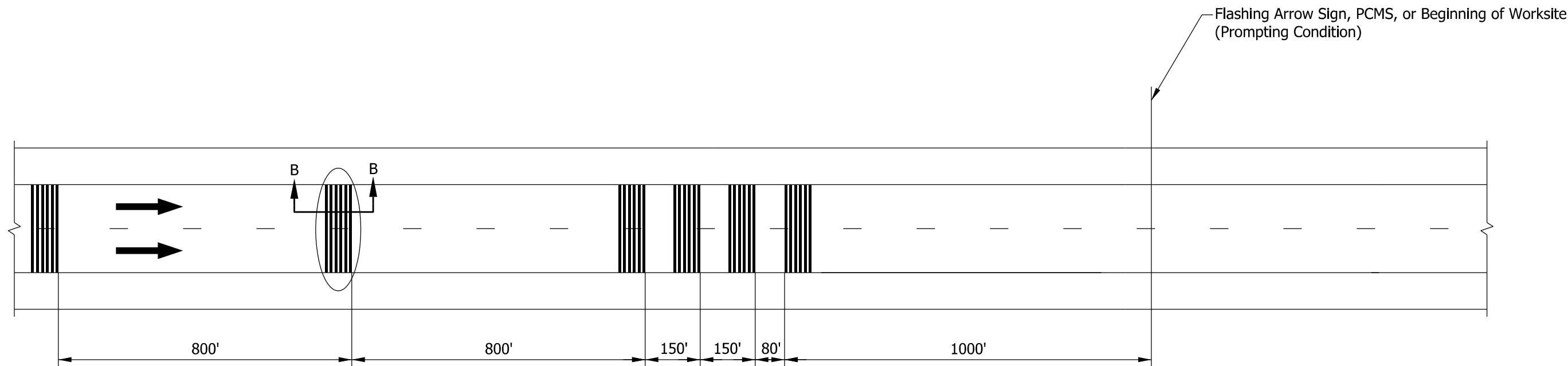

SECTION B-B

LEGEND

→ Direction of Traffic

INDIANA DEPARTMENT OF TRANSPORTATION

TEMPORARY TRANSVERSE RUMBLE STRIPS

SEPTEMBER 2022

STANDARD DRAWING NO. E 801-TCDV-10

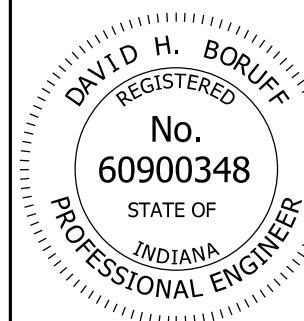

*David H. Boruff* 06/08/22  
DESIGN STANDARDS ENGINEER DATE

*[Signature]* 06/27/2022  
CHIEF ENGINEER DATE

**NOTES:**

1. If not trailer mounted, signs and supports shall satisfy NCHRP 350 or MASH crash evaluation criteria.
- ② See Standard Drawing E 801-TCDV-06 for lateral and vertical placement.
- ③ The speed limit on advance warning signs shall match the worksite speed limit signs.
- ④ The worksite speed limit shall be at least 10 mph but no more than 15 mph below the permanent posted speed limit for the roadway under construction unless otherwise shown on the plans.
5. Sign series shown is for freeway or expressway application.

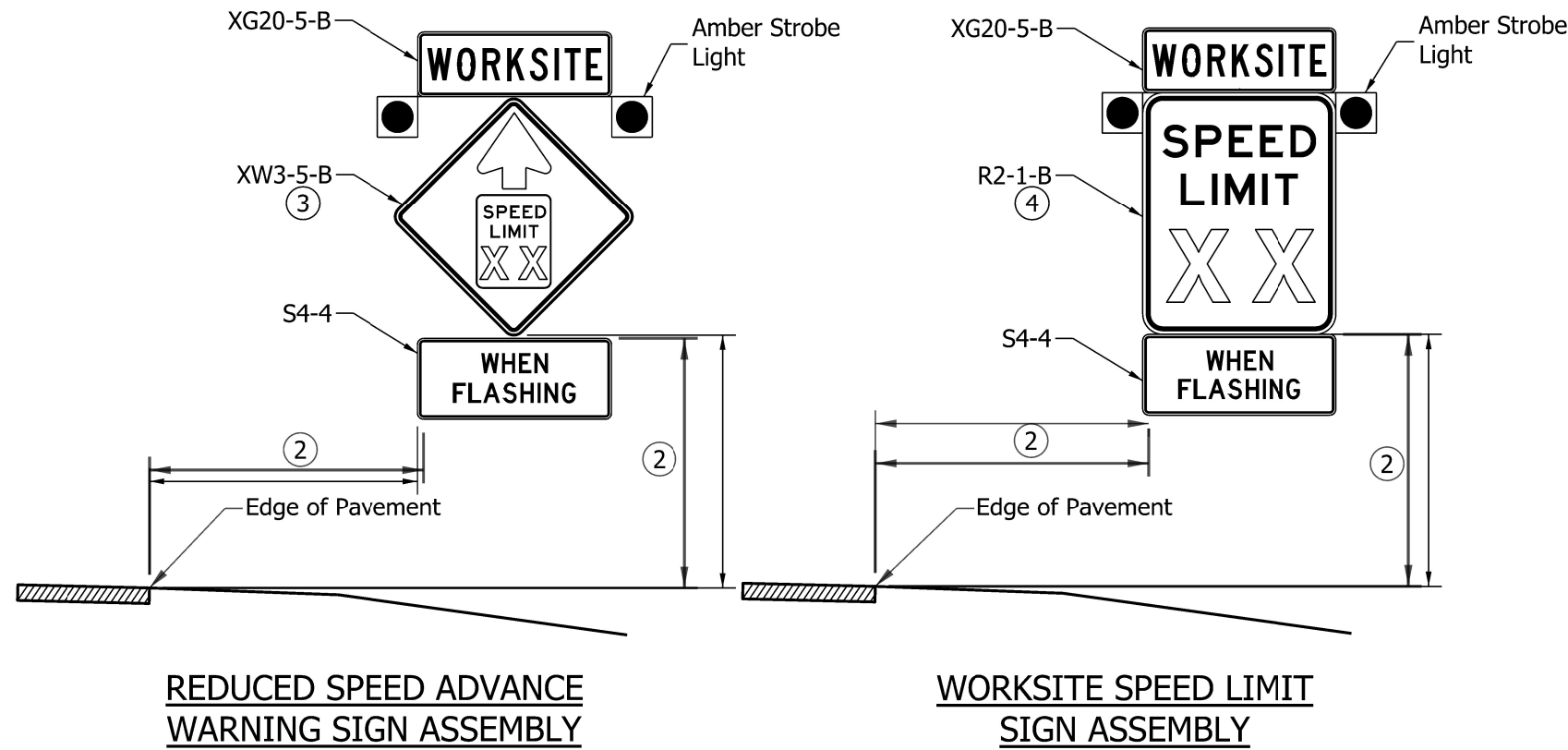

INTERMITTENT USE TYPE

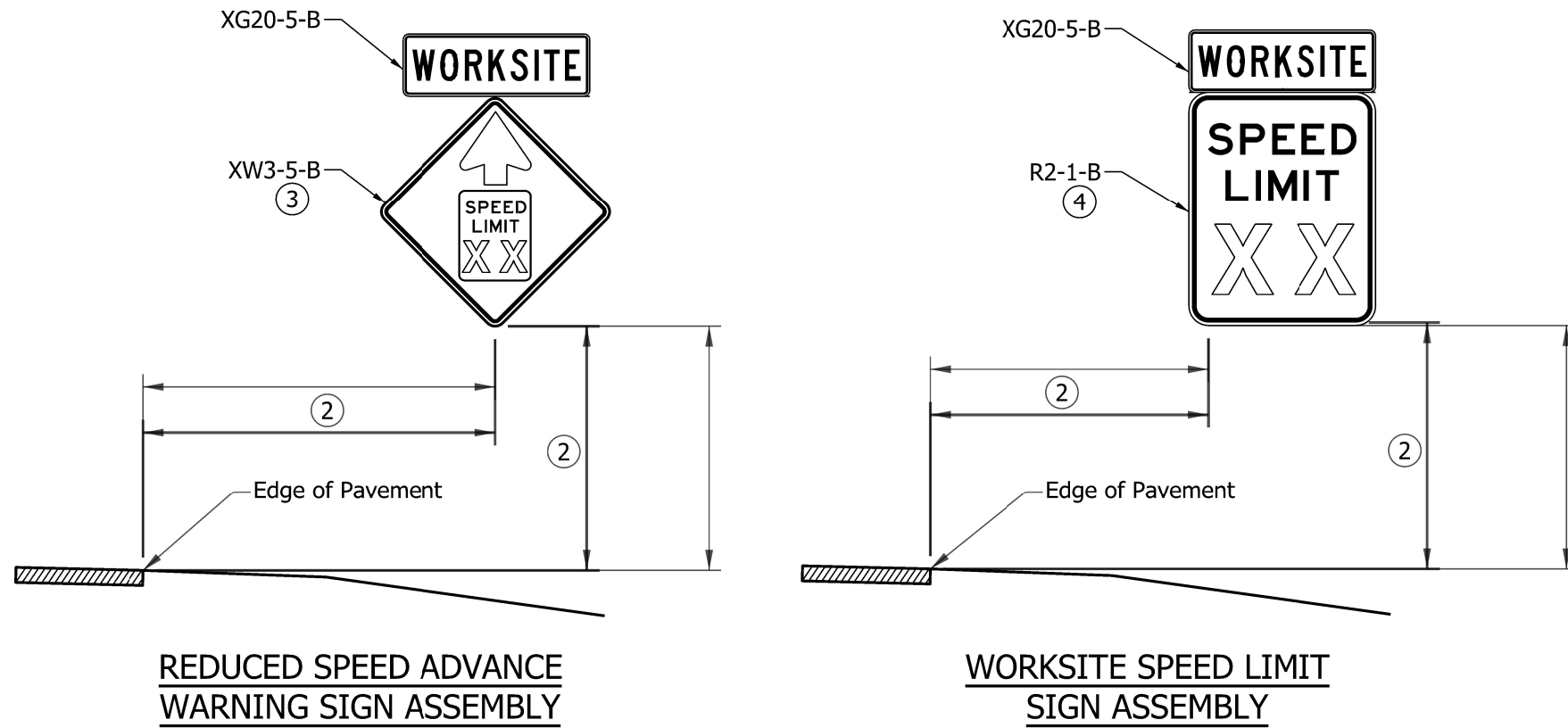

CONTINUOUS USE TYPE

INDIANA DEPARTMENT OF TRANSPORTATION	
WORKSITE SPEED LIMIT SIGN ASSEMBLY	
SEPTEMBER 2022	
STANDARD DRAWING NO. E 801-TCDV-11	
	<p style="text-align: right;"><i>David H. Boruff</i> 06/08/22 DESIGN STANDARDS ENGINEER DATE</p> <p style="text-align: right;"><i>[Signature]</i> 06/27/2022 CHIEF ENGINEER DATE</p>

**NOTES:**

- ① Worksite speed limit sign assemblies shall be placed on both sides of the directional lanes when multiple lanes traveling in the same direction are open to traffic. For undivided roadways, or on roadways where a single lane is open in one direction, assemblies are required on only one side of the roadway.
- ② Assembly spacing may be reduced using Distance B from Table 6C-1 of the IMUTCD for Urban and Rural Roadways.
- 3. Worksite speed limit sign assemblies shall be placed 500 ft beyond each crossroad or the last entrance ramp for each interchange, at 1 mile intervals throughout the worksite, or adjacent to the existing normal speed limit signs.
- ④ For a rural Interstate route application, a truck speed limit sign shall be used and placed immediately to the right of the normal speed limit sign.
- 5. See Standard Drawing E 801-TCDV-11 for worksite speed limit sign assembly.

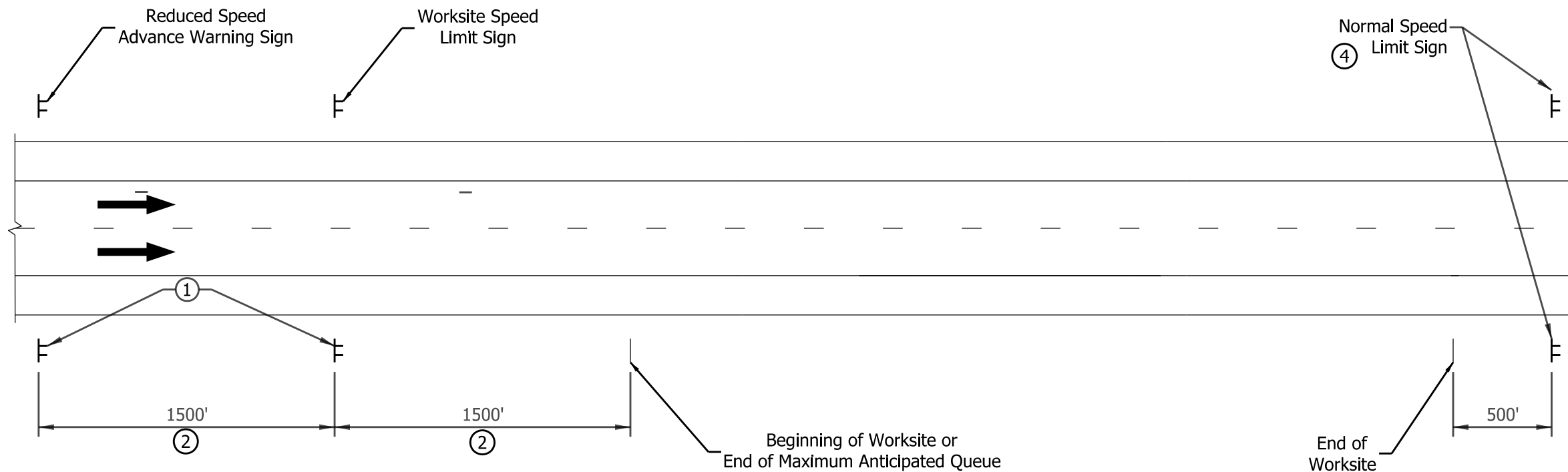

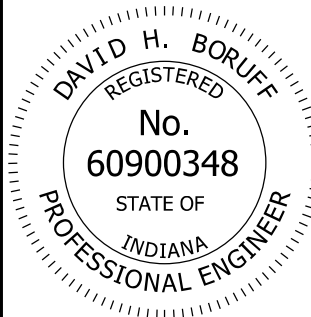
INDIANA DEPARTMENT OF TRANSPORTATION									
WORKSITE SPEED LIMIT SIGN ASSEMBLY LONGITUDINAL PLACEMENT SEPTEMBER 2022									
STANDARD DRAWING NO. E 801-TCDV-12									
	<table style="width: 100%; border-collapse: collapse;"> <tr> <td style="text-align: center; padding: 5px;"><i>David H. Boruff</i></td> <td style="text-align: right; padding: 5px;">06/08/22</td> </tr> <tr> <td style="text-align: center; padding: 5px;">DESIGN STANDARDS ENGINEER</td> <td style="text-align: right; padding: 5px;">DATE</td> </tr> <tr> <td style="text-align: center; padding: 5px;"><i>[Signature]</i></td> <td style="text-align: right; padding: 5px;">06/27/2022</td> </tr> <tr> <td style="text-align: center; padding: 5px;">CHIEF ENGINEER</td> <td style="text-align: right; padding: 5px;">DATE</td> </tr> </table>	<i>David H. Boruff</i>	06/08/22	DESIGN STANDARDS ENGINEER	DATE	<i>[Signature]</i>	06/27/2022	CHIEF ENGINEER	DATE
<i>David H. Boruff</i>	06/08/22								
DESIGN STANDARDS ENGINEER	DATE								
<i>[Signature]</i>	06/27/2022								
CHIEF ENGINEER	DATE								